

DIN 3202 F1 Cast Steel Y-Strainer

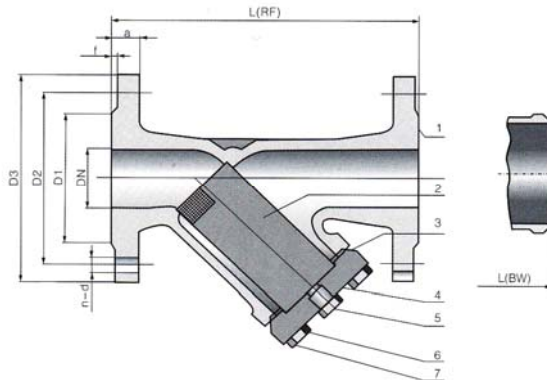

Technical Specification

1. Pressure-temperature ratings: DIN 2401
2. Inspection and Test: ISO 5208、DIN 3203
3. Flanged ends dimension: EN 1092-1、DIN2545 PN40
4. Butt-welded ends dimension: DIN 3239
5. Face to face and end to end: DIN 3202 F1、EN558-11 serial

Main Parts Material

NO	Part Name	Material		
		WCB/SS304	CF8/SS304	CF8M/SS316
1	Body	A216 GR.WCB	A351CF8	A351CF8M
2	Screen	A276 Type 304	A276Type304	A276Type316
3	Gasket	SS304+Graphite	SS304+Graphite	SS304+Graphite
4	Bonnet	A216GR.WCB	A351CF8	A351CF8M
5	Plug	ASTM A105	A182F304	A182F316
6	Bonnet Bolt	A193GR.B7	A193B8	A193B8M
7	Bonnet Bolt Nut	A194GR.2H	A1948	A1948M

Main Dimensions And Weight

DN	L(RF)	L(BW)	D	D1	D2	n-d	B	F	H	Kg
15	130	130	95	65	45	4-14	16	2	85	4
20	150	150	105	75	58	4-14	18	2	95	5
25	160	160	115	85	68	4-14	18	2	110	6
32	180	180	140	100	78	4-18	18	2	125	8
40	200	200	150	110	88	4-18	18	3	145	10
50	230	230	165	125	102	4-18	20	3	155	13
65	290	290	185	145	122	8-18	22	3	175	19
80	310	310	200	160	138	8-22	24	3	210	24.5
100	350	350	235	190	162	8-26	24	3	230	35
125	400	400	270	220	188	8-26	26	3	270	51
150	450	450	300	250	218	8-26	28	3	300	71
200	600	600	375	320	285	12-30	34	3	385	144
250	730	730	450	385	345	12-33	38	3	535	178
300	850	850	515	450	410	16-33	42	4	680	285